

Development of Graphical User Interface (GUI) for Dead Reckoning System of a Non-holonomic Mobile Robot

M. Hassan Tanveer, D. Hazry, S. Faiz Ahmed, M. Kamran Joyo, Faizan. A. Warsi, Zuradzman M. Razlan, Khairunizam Wan, A. T. Hussain

Center of Excellence Unmanned Aerial Systems (COEUAS), Universiti Malaysia Perlis (UniMAP), Perlis, Malaysia.

ARTICLE INFO

Article history:

Received 20 November 2013

Received in revised form 24

January 2014

Accepted 29 January 2014

Available online 5 April 2014

Keywords:

Dead reckoning, Non-holonomic, Mobile robot, Visual basic

ABSTRACT

This article presents the creation of GUI for the dead reckoning nonholonomic mobile robot and verifies the completion of designing a user-friendly GUI for controlling and operating, which will help the user to understand the positioning of the robot. The foremost concern is to design the GUI by using Visual Basic software. Moreover, software such as Solid Works and AutoCAD are also used to design 3D model of the robot.

INTRODUCTION

Mobile Robot is like a vehicle that can move around in an environment and it require devices such as power sources, computational resources, sensors and actuators to be equipped and mounted on the robot for performing a designated task. In this article, the use an autonomous mobile robot which non-holonomic constraint is an experiment tool. In an autonomous mobile robot system, one of the important aspects is related to its motion and navigation control (Sehestedt, 2010). The issue of navigation control becomes more complex when the mobile robot has a non-holonomic system where the system is described by a set of parameters subject to differential constraints, such that when the system evolves along a path in its parameter space, the parameters varying continuously in values but finally returns to the original set of values at the start of the path (Li-Li, 2011). Therefore, the non-holonomic constraint states that the mobile robot can only move in the direction normal to the axis of the driving wheel where it is satisfies the condition of pure rolling without slip. Mobile robots are the focus of a great deal of current researches and almost every major universities has laboratories that focus on mobile robot research or design. A typical robot have a movable physical structure, motors, sensors, power supply and a computer that acts as the robot's brain and controls all of the other elements (Dudek, 2010). However, mobile robot is an automatic machine that can traverse on any kinds of terrain and not limited to a specific area (Zhao, 2010).

Furthermore, a mobile robot is suitable for a variety of applications in unstructured environments where a high degree of autonomy is required (Chen, 2012). This desired autonomous or intelligent behavior has motivated an intensive research in the last decade. Mobile robots are mostly found in industrial (Gascueña, 2011), military (Chen, 2012) and security environments (Klančar, 2011). They also appear as consumer products, for entertainment (Chung, 2012) or to perform certain tasks like vacuum (Mautz, 2011), gardening (Chang, 2012) and some other common household tasks (Ciocarlie, 2012). Mobile robots helps human in many ways like for exploring of planet (Yue, 2011) or inhospitable areas on Earth (Johnson, 2013), collecting geological samples (Jian, 2011), seek out landmines in former battlefields (Chen, 2011). The police force sometimes uses mobile robots to search out for bombs (Habib, 2011), or even to apprehend suspects. Hospitals may use robots to transport medications (Bloss, 2011). Some museums use robots for monitoring air quality and humidity levels (Rosenthal, 2012). As the demands for mobile robots in a wide array of applications increases thus the need for robust tracking control of the mobile robots is clearly understood. Hence, a closed-loop sensor based controller is required. For user friendly and easy robot operation, the mobile robot must be developed and equipped with Graphical User Interface (GUI).

MATERIAL AND METHODS

In addition to visual components, graphical user interfaces also make it easier to move data from one application to another. A true GUI includes standard formats for representing text and graphics because the formats are well-defined so different programs that run under a common GUI can share data. Furthermore, GUI is an important part of software application to enhance the efficiency and to ease of user for the understanding logical design of stored program and design discipline. As a robot hobbyist, user can use software to design their own GUI to interface with microcontroller circuit board, motor controller, PIC Interface Kit etc.

In this article, development of a Nonholonomic Mobile robot known as 'AMAD-R' is done as an experimental validation tool and it is shown in Fig. 1.

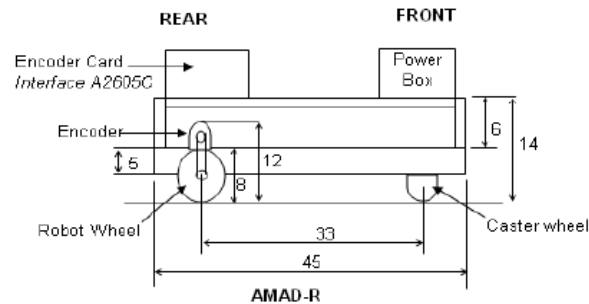

Fig. 1: Structure of the Mobile Robot.

Table 1 shows the mechanical specification of the robot. The robot is equipped with encoder sensor on the both side of the rear wheel connected by the rubber chain in-order to decode the position of the mobile robot and the speed of the wheels. The resolution of the optical quadrature encoder is 1024 pulse/ rev. The mobile robot uses 8cm in diameters' of wheel so that the each pulse of the encoder could counter a distance of $8 \times 3.1415 / 1024 = 0.02454$ cm per pulse.

Table 1. Mechanical specification

Height	14 cm
Width	46 cm
Length	45 cm
Radius of 2 driving wheels: r	4 cm
Circumference of wheel: $2\pi r$	25.1327 cm
Distance between 2 wheels: 2d	43 cm

The system configuration of mobile robot is shown in Fig. 2.

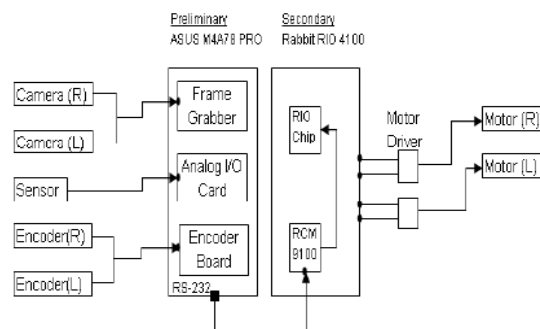

Fig. 2: Robot Block Diagram.

RESULT AND DISCUSSION

Besides two encoders are connected to the DC motors, one unit of ultrasonic sensor is also installed at the front of the mobile robot for sensing and obstacle avoidance. Two units of CCD Camera is planned to be mount to the mobile robot for image recognition and navigation. The mobile robot is already equipped with Frame Grabber and Graphic card for image processing. In the future development, more ultrasonic sensor and other sensor will be attached to this mobile robot. All signals from the various sensors will processed by the Interface Analog

Input-Output PCI-A3521 card. Interface encoder PCI-A6205C card is mounted on the computer motherboard ASUS M4A78 PRO for converting encoder output signal and send it to secondary processor Rabbit RIO RCM4100. Rabbit RIO processor will process the data and converting it to PWM signal for controlling the speed of DC motors which steer the mobile robot during it trajectory tracking.

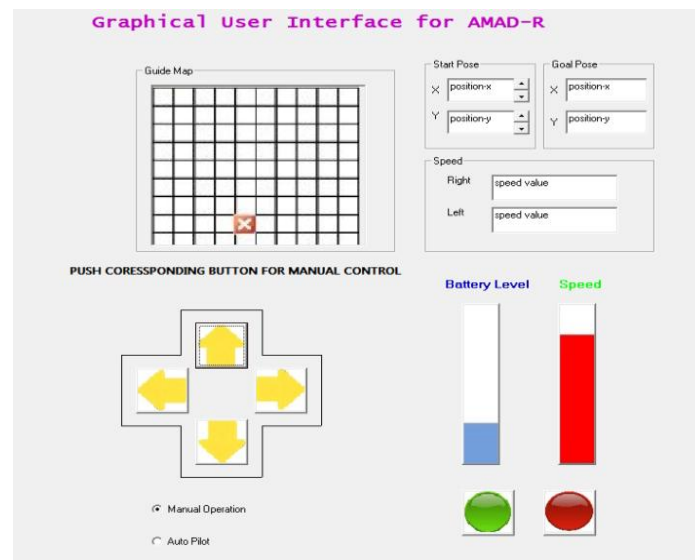

Fig. 3: GUI Design.

Conclusion:

In this article, from the designing and testing process, we succeeded in creating an efficient GUI that displays accurate data to the user in an easy-to-interpret. This accomplishes beneficial interaction functionality because of its collaboration between a software and hardware solution. Future work will focus on the lessons learned from this experiment, particularly designing more accurate GUI to interface which will be more simple and straight forward.

REFERENCES

- A Report: Dudek, Gregory, and Michael Jenkin. Computational principles of mobile robotics. Cambridge university press, 2010.
- A Report: Jian, J. I. A. O. "Design of Rolling Device of Fiber-Type Mine Rescue Robot." China Public Security (Academy Edition) 2 (2011): 018.
- A Report: Johnson, Les. "2 Space War." Sky Alert!. Springer New York, 2013. 31-42.
- A Report: Li-Li, X. I. A. "A Field Integration Method for a Nonholonomic Mechanical System of Non-Chetaev's Type." Chinese Physics Letters 28.4 (2011): 040201.
- Conference Proceedings: Chang, Chung-Liang, Jian-Fong Chen, and Jia-Heng Jhu. "Design and Implementation of a Gardening Mobile Robot with Embedded Face-Tracking System." IEEE International Symposium on Intelligent Signal Processing and Communication Systems (ISPACS 2012). 2012.
- Conference Proceedings: Ciocarlie, Matei, *et al.* "Mobile manipulation through an assistive home robot." Intelligent Robots and Systems (IROS), 2012 IEEE/RSJ International Conference on. IEEE, 2012.
- Conference Proceedings: Habib, M. K., Y. Baudoin, and F. Nagata. "Robotics for rescue and risky intervention." IECON 2011-37th Annual Conference on IEEE Industrial Electronics Society. IEEE, 2011.
- Conference Proceedings: Mautz, Rainer, and Sebastian Tilch. "Survey of optical indoor positioning systems." Indoor Positioning and Indoor Navigation (IPIN), 2011 International Conference on. IEEE, 2011.
- Conference Proceedings: Sehestedt, Stephan, Sarath Kodagoda, and Gamini Dissanayake. "Robot path planning in a social context." Robotics Automation and Mechatronics (RAM), 2010 IEEE Conference on. IEEE, 2010.
- Conference Proceedings: Zhao, Cui-Jun, and Guo-Quan Jiang. "Baseline detection and matching to vision-based navigation of agricultural robot." Wavelet Analysis and Pattern Recognition (ICWAPR), 2010 International Conference on. IEEE, 2010.
- Journal Articles: Bloss, Richard. "Mobile hospital robots cure numerous logistic needs." Industrial Robot: An International Journal 38.6 (2011): 567-571.
- Journal Articles: Chen, Chen-Yuan, *et al.* "The development of autonomous low-cost biped mobile surveillance robot by intelligent bricks." Journal of Vibration and Control 18.5 (2012): 577-586.

Journal Articles: Chen, Li Jia, *et al.* "Path Planning for Mobile Robots in 3D Dynamic Environments." *Advanced Materials Research* 403 (2012): 1401-1404.

Journal Articles: Chen, Zujue, Shaoqing Liu, and Jun Huang. "Multi-tier grid routing to mobile sink in large-scale wireless sensor networks." *Journal of Networks* 6.5 (2011): 765-773.

Journal Articles: Chung, Pei-Yin, *et al.* "Influence and dynamics of a mobile robot control on mechanical components." *Journal of Vibration and Control* (2012).

Journal Articles: Gascueña, José Manuel, and Antonio Fernández-Caballero. "Agent-oriented modeling and development of a person-following mobile robot." *Expert Systems with Applications* 38.4 (2011): 4280-4290.

Journal Articles: Klančar, Gregor, Drago Matko, and Sašo Blažič. "A control strategy for platoons of differential drive wheeled mobile robot." *Robotics and Autonomous Systems* 59.2 (2011): 57-64.

Journal Articles: Rosenthal, Stephanie, and Manuela M. Veloso. "Mobile Robot Planning to Seek Help with Spatially-Situated Tasks." *AAAI*. Vol. 4. No. 5.3. 2012.

Journal Articles: Yue, Ming, Wei Sun, and Ping Hu. "Sliding mode robust control for two-wheeled mobile robot with lower center of gravity." *International Journal of Innovative Computing, Information and Control* 7.2 (2011): 637-646.