



**INVENTORS**  
 TG. MUHD. AIMAN TG. MOHD YUSOF  
 MUHD. FIRDAUS MOHD RADZI  
 MOHD FIKRI CHE HUSIN  
 AHMAD FARIZ HASAN  
 MOHD NORHAFIZ HASHIM

**CONTACT DETAILS**  
 Department of Electronic Engineering,  
 Faculty of Engineering Technology,  
 Universiti Malaysia Perlis (UniMAP), Kampus  
 Unicity Alam, Sg. Chuchuh, 02100 Padang  
 Besar, Malaysia.  
 E-MAIL : FIKRI@UNIMAP.EDU.MY  
 H/P NO. :013-5235005

# Energy Saving Switched-Mode Regulator in Motorcycle Electrical Power Supply (ESSRM)

## PROBLEMS STATEMENT

Conventional power regulators used in current motorcycles wastes energy in order to regulate output voltage to desired level.

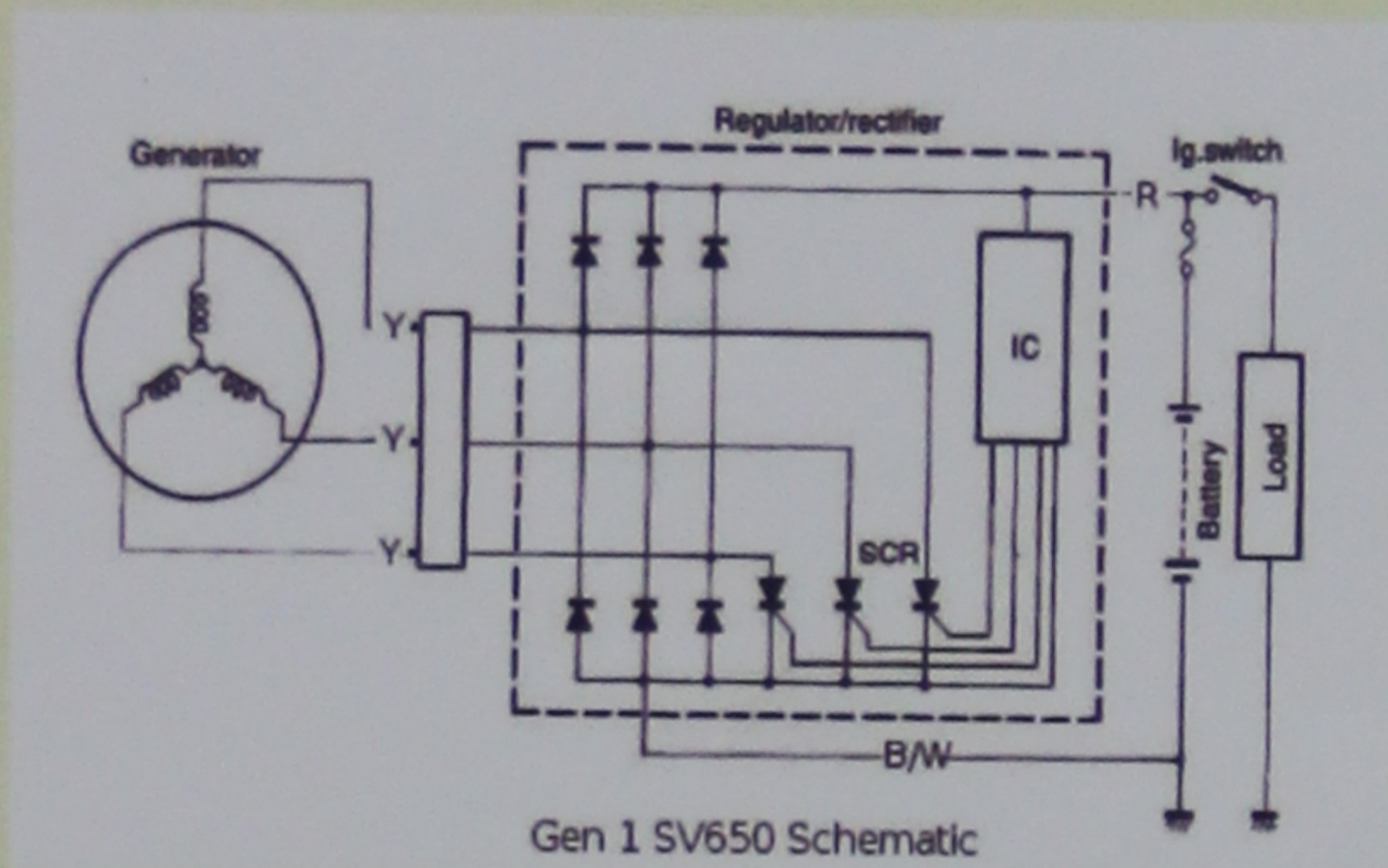

## PRODUCT DESCRIPTION

Switch-Mode Power Supply (SMPS) technology have been around for quite some time and is proven to be more efficient energy conversion compared to linear regulators. Implementing SMPS in motorcycle will save substantial amount of energy and fuel consumption over motorcycle's service life. In addition, battery lifespan will prolong significantly due to stable charge current.

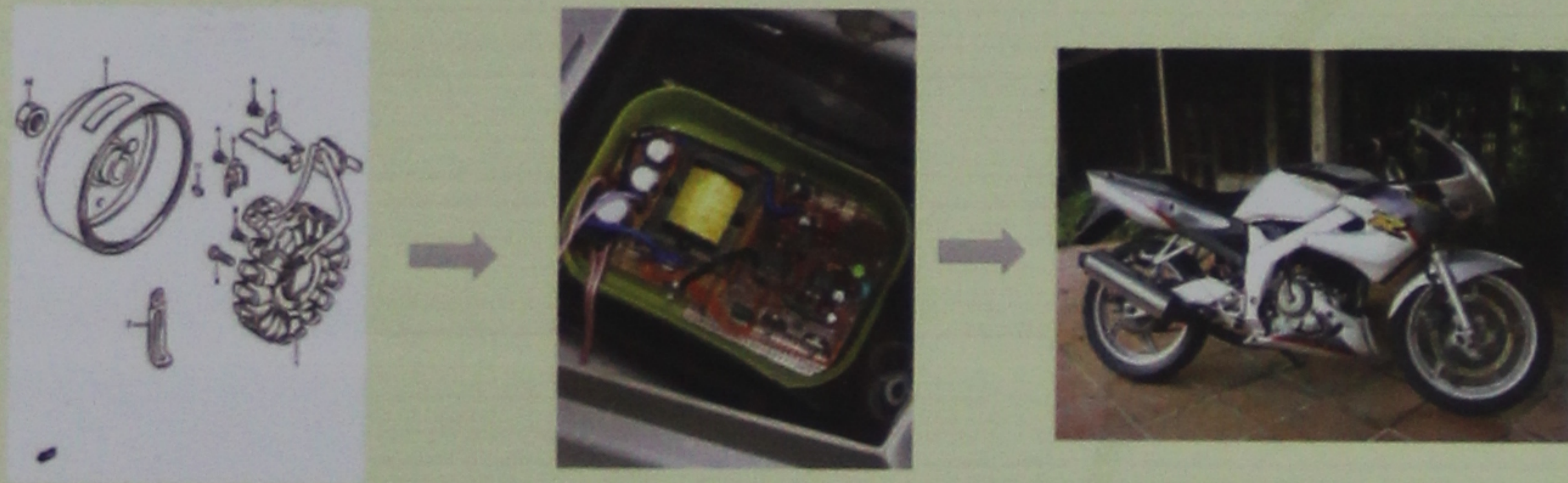

## NOVELTIES

- Implementing SMPS technology in Motorcycle electrical power supply.
- Efficient voltage conversion compared to conventional power regulators.
- Very wide input voltage capability.
- Adjustable output voltage to suit specific needs.

## POTENTIAL APPLICATION

In line with today's greener technology conception, SMPS is the best choice to regulate the unregulated output from motorcycle generator. SMPS is more energy efficient, improves engine performance, reduces fuel consumption and ultimately, reduces carbon footprint.

## PROCESS FLOW

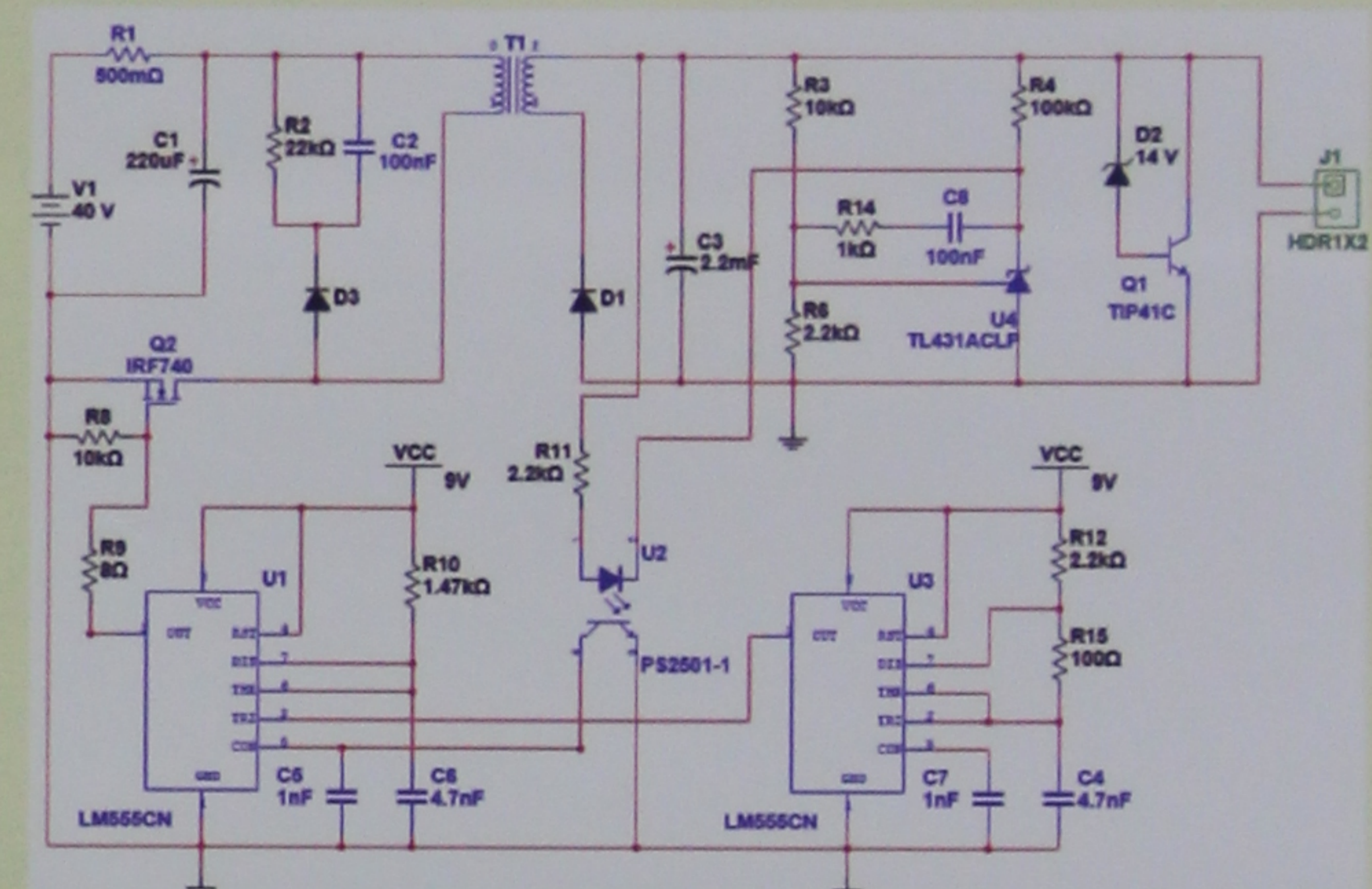

## PRODUCT PERFORMANCES

