

# Study of Inertial Measurement Unit Sensor

D. Hazry      M. Sofian      A. Zul Azfar  
Autonomous System and Machine Vision Laboratory,  
School of Mechatronic, Universiti Malaysia Perlis, Malaysia  
hazry@unimap.edu.my

**Abstract-** This paper contains the study about the inertial measurement unit (IMU) sensor. The study is about the types available in markets and also some research on IMU. In this paper also included the uncertainty of some IMU been used and comparison between some IMU manufacturers. Then the combination of IMU with GPS can provide more effective result for navigation, guidance and controlling system for aircraft such as UAV (unmanned aerial vehicle).

## I. INTRODUCTION

An inertial measurement unit, or IMU, is the main component of inertial guidance systems used in air space, and watercraft, including guided missiles. An IMU works by sensing motion including the type, rate, and direction of that motion using a combination of accelerometers and gyroscopes. Accelerometers are placed such that their measuring axes are orthogonal to each other.

An IMU works by detecting the current rate of acceleration, as well as it changes in rotational attributes, including pitch, roll and yaw. This data is then fed into a computer, which calculates the current speed and position, given a known initial speed and position.

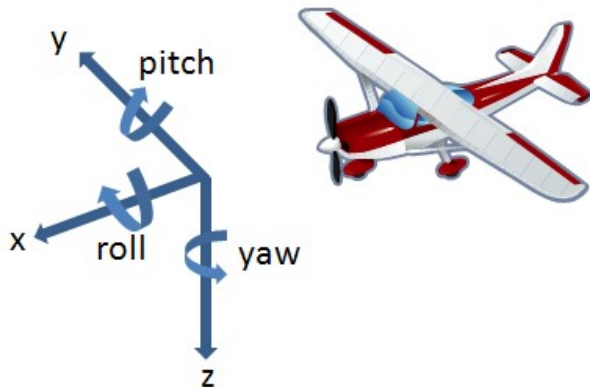

Figure 1. An IMU sensor measures linear acceleration and orientation.

## II. TYPES OF IMU

IMU available in market now are in various types and shape. So, user can select what type, size and shape. The IMU can be selected from its degrees of freedom (DOF) that being developed by manufacturer. User can select from three DOF, five DOF and six DOF. For three DOF, the sensors configurations are two accelerometers and a gyroscope that measures yaw. For five DOF, the sensors configurations are three accelerometers and two gyroscopes that measure pitch

and roll. For six DOF, all axes for accelerometer and gyroscope for measurement are available. The products examples from SparkFun:



Figure 2. Six DOF IMU sensor



Figure 3. Five DOF IMU sensor



Figure 3. Three DOF IMU sensor

## III. RESEARCHES ON IMU

### A. Comparison of HG1700 and Crista MEMS IMU for Navigation

This research is done by integrating GPS/inertial navigation system that uses commercial off-the-shelf Micro-Electro-Mechanical System (MEMS) accelerometers and gyroscopes. The MEMS inertial measurement unit (IMU) is packaged in a small size and provides the raw IMU data through a serial interface to a processor board where the inertial navigation solution and integrated GPS/inertial Kalman filter is generated [1]. The IMUs used in this research are HG1700 IMU from Honeywell and Crista IMU from Cloud Cap.



Figure 4. Honeywell HG1700



Figure 5. Cloud Cap Crista IMU

The HG1700 integrated GPS/inertial solution has been extensively tested as a TSPI (Time Space Position Information) reference system in [2] and so was used as the truth reference. The comparison of the position and attitude solutions between the HG1700 and the Crista MEMS integrated navigation solution is shown in Figure 6 to Figure 10.

The GPS-aided Crista solution performed well in observing the position and tilt of the vehicle. As expected, the heading accuracy was much poorer than possible with the HG1700. The previous testing with the HG1700 has demonstrated alignment accuracies of better than 0.06 degrees (1 mrad) [2]. With the Crista IMU, the heading accuracy was only 2 degrees (35 mrad).

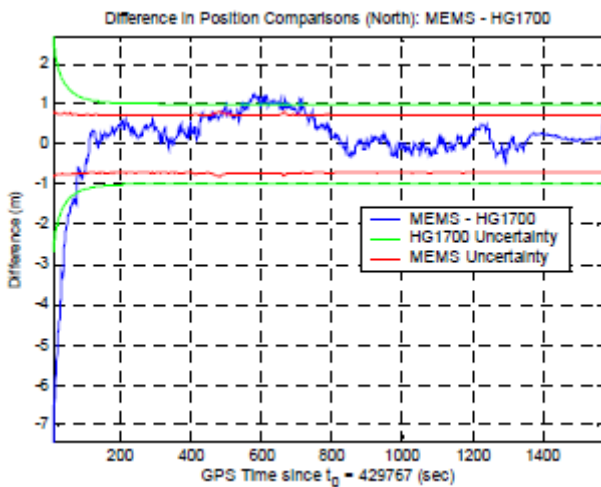

Figure 6. North Position Error

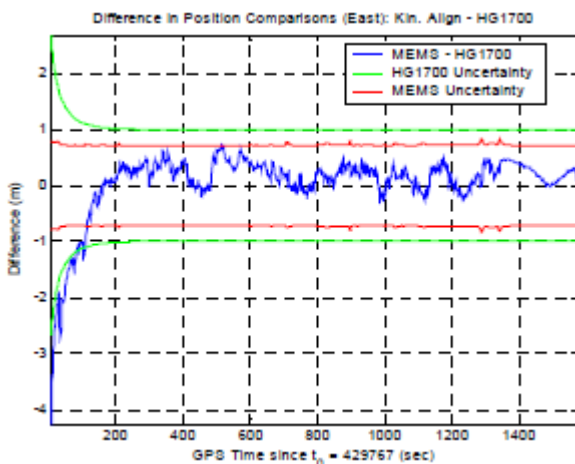

Figure 7. East Position Error

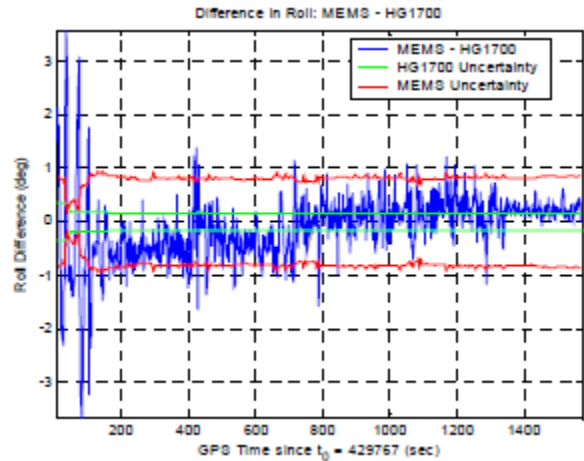

Figure 8. Roll Error

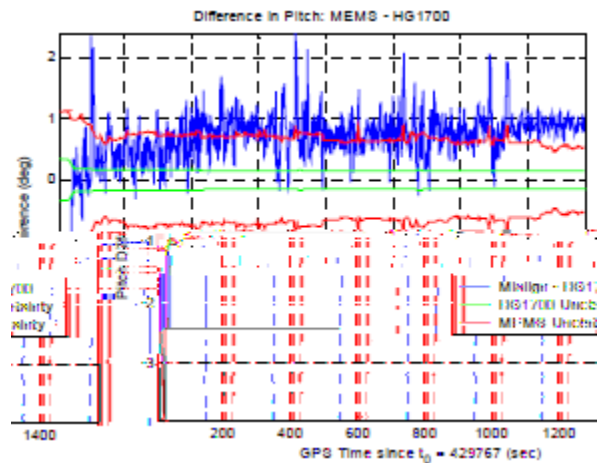

Figure 9. Pitch Error

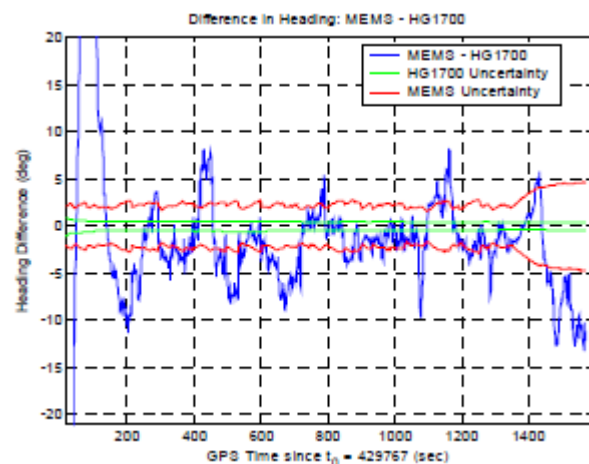

Figure 10. Heading Error

Those figure 6 to figure 10 show the error readings for Honeywell HG1700 and Crista MEMS IMU. The green line is the uncertainty reading for HG1700 and red line is the uncertainty reading for Crista MEMS IMU. Then, the blue line is the uncertainty value differences between them.

TABLE 1  
IMU Gyroscope and Accelerometer Parameter Comparison [1]

Parameters	UNITS	HG1700	Crista
	Type	Ring Laser Gyro	MEMS
Size		33 cu in	1.6 cu in
Weight		32 oz	0.7 oz
Power		8 w	0.7 w
<b>Gyroscopes</b>			
Operating Range	$\pm^\circ/s$	1000	300
Scale factor accuracy ( $1 \sigma$ )	ppm	150	25000
Scale factor linearity $1 \sigma$ to $\pm 800^\circ/s$	ppm	150	N/A
Bias ( $1 \sigma$ )	$^\circ/\text{hour}$	2	500
Axis alignment stability ( $1 \sigma$ )	$\mu\text{rad}$	500	3000
Axis alignment stability, non-orthogonality ( $1 \sigma$ )	$\mu\text{rad}$	100	N/A
Output noise ( $1 \sigma$ of 10,000 samples)	$\mu\text{rad}$	80	80
Angular random walk max.	$^\circ/\text{Rt-hr}$	0.1	3
<b>Accelerometers</b>			
Operating Range	$\pm g$	50	10
Scale factor accuracy ( $1 \sigma$ )	ppm	300	25000
Scale factor linearity ( $1 \sigma$ )	ppm	500	N/A
Bias ( $1 \sigma$ )	mg	1.0	15000
Axis alignment stability ( $1 \sigma$ )	$\mu\text{rad}$	500	3000
Axis alignment stability, non-orthogonality ( $1 \sigma$ )	$\mu\text{rad}$	100	N/A
Output noise ( $1 \sigma$ of 10,000 samples)	m/s	0.0024	0.0003
Velocity random walk	( $\mu g/\text{Rt-Hz}$ )	150	400

Table 1 shows the comparison for gyroscope and accelerometer parameters between HG1700 and Crista IMU. This comparison is used to select the best IMU to be used in navigation system in [1]. The results seems the Crista IMU from Cloud Cap is better with smaller size, less weight, low power consumption and more accurate than HG1700 IMU from Honeywell.

### B Real-Time Navigation, Guidance and Control of a UAV [3]

This project is about using the IMU sensor and global positioning system (GPS) for real time navigation, guidance and control (GNC) of an uninhibited aerial vehicle (UAV). The INS/GPS (Inertial Navigation System/Global Positioning System) navigation loop provides continuous and reliable navigation solutions to the guidance and flight control loop for autonomous flight. With additional air data and engine thrust data, the guidance loop computes the guidance demands to

follow way-point scenarios. The flight control loop generates actuator signals for the control surfaces and thrust vector. The whole GNC algorithm was implemented within an embedded flight control computer. The real-time flight test results show that the vehicle can perform the autonomous flight reliably even under high maneuvering scenarios.

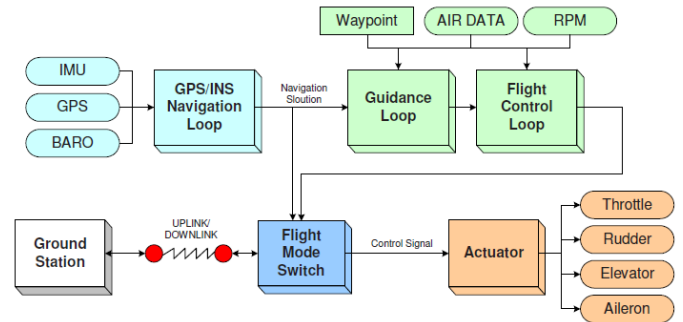

Figure 11. The overall structure of navigation, guidance and control loop in UAV

Figure 11 shows the overall GNC structure implemented in the Flight Control System (FCS). In remote operation mode, the remote pilot on the ground sends the control signals to the actuator via wireless uplink channel. The INS/GPS navigation loop downlinks the vehicle states to the ground station for vehicle state monitoring. When the autonomous mode is activated, the navigation solution is fed into the guidance and control loop and the onboard Flight Mode Switch (FMS) redirects the computed control outputs to the actuators.

The INS/GPS navigation loop makes use of a four-sample quaternion algorithm for the attitude update [4]. A complementary Kalman filter is designed with the errors in position, velocity and attitude being the filter states. It estimates the low-frequency errors of the INS by observing the GPS data with noises. In actual implementation, a U-D factorized filter is used in order to improve the numerical stability and computational efficiency [5][6]. Under high maneuverability, part of the GPS antenna can be blocked from the satellite signals which cause the receiver to operate in 2D height-fixed mode; hence to maximize the satellite visibility under these conditions, a second redundant receiver is installed and used.

The guidance loop generates the guidance commands from the vehicle states and the desired waypoint information. It computes required vehicle speed with respect to the air, height and bank angle. Then the flight control loop (or autopilot) generates actuator control signals to make the vehicle follow the guidance demands as well as to stabilize the vehicle. The control outputs are fed to the control surfaces, or aileron, elevator and rudder, and thrust vector [7][8].

The navigation loop plays a key role in aircraft system. Its navigation outputs are used in guidance and control and affect the performance of target registration and picture compilation tasks. It also has to provide precise timing synchronization to other sensor nodes. The core of the navigation loop is the strap down INS and the Kalman filter. The strap down INS provides

continuous and reliable position, velocity and attitude with sufficiently high rates. The Kalman filter estimates the navigation errors by blending the GPS observation or baro-altimeter data running as a background task.

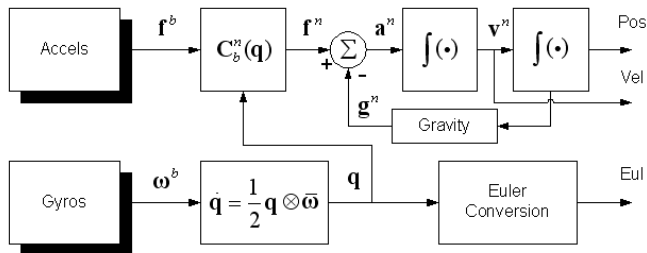

Figure 12. The INS mechanization in the earth-fixed tangent frame.

The INS is mechanized in an earth-fixed tangent frame as shown in figure 12. It computes position, velocity and attitude of the vehicle with respect to the reference frame by numerical integration of the accelerations and angular rates. In this mechanization scheme, the reference frame is assumed as a non-rotating inertial frame. The short mission flight time and the frequent GPS corrections make this assumption valid without significant performance degradations in most of the local terrestrial navigators. If the INS should perform long-range missions without GPS corrections, the INS will require a more precise mechanization scheme to remove systematic errors like frame rotation effect and coriolis force. In this earth-fixed tangent frame mechanization, the coriolis and transport rates term are not calculated.

The navigation outputs are in MGA (Map Grid Australia) coordinate format instead of WGS-84 coordinate as it is convenient to exchange the vehicle states and relative target observations between multiple UAVs.

The fusion Kalman filter is the heart of the navigation system. In a low-cost system the IMU errors like bias, scale factor error and random walk noise dominate the INS error growth. These INS errors typically show low dynamics and its models have been well developed [9]. The INS error model in earth-fixed tangent frame is used in [10].

#### IV. CONCLUSION

From the study, IMU seems can be used in many application. For future project, this study of IMU wanted to be applied to quadrotor unmanned aerial vehicle (UAV) which will be used as flight stabilizer controller. The function of IMU that can measure the pitch, roll and yaw of UAV is the main type sensor that must be used for that application beside it can be implemented with auto pilot system. IMU sensor also can be combined with other sensor such as GPS for accurate navigation, guidance and controlling system.

#### ACKNOWLEDGMENT

A special thanks to Dr. Hazry Desa and Mr. Sofian for their advices and guidance in finishing this paper. Thanks also to AutoMAV team for supports and teamwork.

#### REFERENCES

- [1] Alison K. Brown, Test Results of a GPS/Inertial Navigation System Using Low Cost MEMS IMU, NAVSYS Corporation, 14960 Woodcarver Road, Colorado Springs, CO 80921 USA.
- [2] A. A. Santiago. Extended Kalman Filtering Applied to A Full Accelerometer Strapdown Inertial Measurement Unit. Master's Thesis, Department of Aeronautics and Astronautics, Massachusetts Institute of Technology, 1992 Ari Yosef Benbasat, An Inertial Measurement Unit for User Interfaces, School of Architecture and Planning, Massachusetts Institute of Technology, 2000.
- [3] Jong-Hyuk Kim, Salah Sukkarieh, and Stuart Wishart, "Real-Time Navigation, Guidance, and Control of a UAV Using Low-Cost Sensors", Australian Centre for Field Robotics School of Aerospace, Mechanical and Mechatronic Engineering University of Sydney, NSW 2006, Australia and BAESystems Australia.
- [4] P. G. Savage, "Strapdown Inertial Navigation Integration Algorithm Desogn Part I: Attitude Algorithms," *Journal of Dynamic Systems, Measurement and Control*, vol. 21, no. 1, pp. 19–28, January-February 1998.
- [5] M. Grewal and A. Andrew, *Kalman Filtering - Theory and Practice*. Prentice-Hall, Inc., 1993.
- [6] J.H. Kim and S. Sukkarieh. Flight Test Results of a GPS/INS Navigation Loop for an Autonomous Unmanned Aerial Vehicle (UAV). In *Proceedings of the 15th International Technical Meeting of the Satellite Division of the Institute of Navigation*, pages 510–517, September, OR, USA, 2002.
- [7] B.L. Stevens, F.L. Lewis, *Aircraft Control and Simulation*, John Wiley and Sons, Inc., 1992.
- [8] Skogestad, Postlethwaite, *Multivariable Feedback Design*, John Wiley and Sons, Inc., 1997.
- [9] D.G. Meskin and I.Y. Bar-Itzhack, "Unified Approach to Inertial Navigation System Error Modeling," *Journal of Guidance, Control, and Dynamics*, vol. 15, no. 3, pp. 648–653, May-June 1992.
- [10] S. Sukkarieh, "Aided Inertial Navigation Systems for Autonomous Land Vehicles," PhD thesis, Australian Centre for Field Robotics, The University of Sydney, 1999.