

Performance of Thermal Electric Cooling (TEC) Air Condition for A Small Office Space

Muhammad Syahril Abd Aziz¹, Shamsul Anuar Shamsudin^{1*}, Mohd Farid Ismail², Mohd Nizam Sudin¹ and Huthaifa Ahmad Al-Issa³

¹Fakulti Kejuruteraan Mekanikal, Universiti Teknikal Malaysia Melaka, Technology Campus, 75450 Ayer Keroh, Melaka, Malaysia

²Fakulti Teknologi Kejuruteraan Mekanikal dan Pembuatan, Universiti Teknikal Malaysia Melaka, Technology Campus, 75450 Ayer Keroh, Melaka, Malaysia

³Electrical and Electronics Engineering Department, Al Balqa Applied University, Jordan

ABSTRACT

An experimental investigation on the TEC (thermoelectric cooler) air-conditioner with evaporative cooler that acts as condensing unit in a small office space was performed. Various engineering performance criteria of the system such as the Coefficient of Performance (COP) of the TEC plate, the COP of the developed product, the COP of evaporative cooler and the sound level of the product were evaluated. The tested area office size was 12 ft × 11 ft, used for light activities and with few equipment generating heat. As a result, the TEC air conditioner by evaporative cooling was developed that consists of several parts that include thermoelectric modules model TEC-12706, heatsink-fan, water heatsink, water pump, water pipeline, radiator, and evaporative cooler. This experiment found that the COP of the TEC plates condensed by evaporative cooling is 0.39. The optimum running current for the system is 5 A when the system's COP achieved the highest values which is 1.7. The COP of the evaporative cooling decreases with the increment of the current supply to the TEC. Consequently, the 62.9 dB sound level of the system is acceptable.

Keywords: TEC, comfort, energy, sound, evaporative.

1. INTRODUCTION

All buildings in Malaysia use air conditioning to cool the air inside. Not only in large buildings, but even small offices need cool air to ensure a comfort zone. Each air conditioning system has a variety of cooling and heating capacity that are required. Besides that, all of these systems are using almost similar mechanisms to work. There are several main types of air conditioning systems such as single split, multi split, portable package and variable refrigerant flow system. These systems mostly use vapor compression cycle directly to cool the indoor air even for small loads. The usage of refrigerant would be commonplace to run the system as refrigerant is a medium of transferring heat for the system. Researchers in [1] evaluated the performance of air conditioner using various types of refrigerants such as R32, R410a and R22. Unfortunately, the usage of refrigerants generally is not environmentally friendly which can lead to ozone depletion and global warming as most of them are hydro chlorofluorocarbon (HCFC) refrigerants. The work in [2] evaluated the amount of chlorine released to stratospheric space and how it affects the ozone depletion. Moreover, the work in [3] also mentioned that the highest ozone depletion potential (ODP) and global warming potential (GWP) is by R22 which recorded values of 0.05 and 1810 as compared to those by R32, R410a and R22. Hence, the

advantage of TEC air conditioner is a free refrigerant system to provide cooling effect which can reduce the damage toward environment.

There are various studies about the compressor-based air conditioners and each type has different cooling capacity as shown in Table 1. Hence, each of compressor-based unit type has individual characteristics that suits various of applications. For a personal office application, the low heat requires less cooling capacity to maintain the temperature to achieve thermal comfort. Unfortunately, none of the studies above considered low capacity where the lowest cooling capacity generated is 8000 btu/hr for a conventional air conditioner. Currently, the conventional unit serving the low load space would provide excessive cooling that will lead to energy wastage. [8] stated that normal range of heat load of private office is 3000 to 5000 btu/hr. The generated cooling capacity is higher than the required cooling capacity which consume more power consumption to generate unnecessary cooling effect as the personal office is only need not more than 5000 btu/hr. Therefore, this study come out with alternative way to provide cooling for a small personal office by using TEC as the source of cooling effect.

Table 1 Recent studies contribute to cooling capacity for compressor-based unit

Reference	Type of air conditioner	Topic/Technology	Cooling capacity (btu/hr)
[4]	Split unit	Dynamic characteristic in shutdown/startup condition	9,000 – 30,000
[5]	Multi split unit	Various size opening of electronic expansion valve	8,500 – 25,000
[6]	Portable package unit	Transient model/system analysis	8,000 – 30,000
[7]	Variable refrigerant flow unit	Load responsive of evaporator for energy saving	8,500-520,000

The use of the TEC includes thermoelectric refrigeration, electronic and automobile cooling systems, thermoelectric air conditioning system, photovoltaic-thermoelectric hybrid cooling system, active building cooling system, freshwater production and cooling system for medical purposes. Several methods have been formulated from other studies to enhance the cooling effect of the TEC by treating the hot side of the TEC. The work in [9] conducted various treatment methods to get the best frosting system produce by the TEC such as (a) fan enhanced heat pipe cooling, (b) forced convection water cooling, and (c) forced convection air cooling, and two passive cooling methods based on (d) free convection water cooling, and (e) free convection air cooling. The results showed that the COP were (a) 0.314, (b) 0.309, (c) 0.3174, (d) 0.293, and (e) 0.243. Meanwhile, the work by [10] reported two different heat removal methods that are heat sink fin-fan and a double fan heat pipe, which were used to determine the performance of a cooler box. The results from this study stated that there were no significant differences on COP of the cooler box, but there was an increase in the temperature difference. According to [11] they improved the COP of Peltier air cooler by around 50% with the use of perforating method instead of a simple heat sink. Next, a study by [12] developed a water dispenser by sinking the TEC to produce hot water and cold water simultaneously and obtain the COP of the cooling and heating of 2.9 and 3.95, respectively. Nevertheless, none of these studies touch on combining evaporative cooling as medium to treat the hot waste produce by the TEC.

The current work uses Evapolar as a medium of the indirect evaporative cooler, which acts as a small fan that spread air using specialized material. It is not a full air conditioner using refrigerants or having all four basic component systems. It blows air in a small radius of air around 3-4 m around us and humidifies the air around us. The working principle of Evapolar is

filled with the removable tank with water and biodegradable fiber cartridge will absorb the water. Then water spreads evenly on the surface of the cooling pad and evaporates, which makes cool air available that provides thermal comfort with a suitable cooling effect.

2. MATERIAL AND METHODS

In order to conduct the analysis performance of the TEC air conditioner condensed by evaporative cooling, the first and foremost thing is to know the whole system components, functioning and configuration of the portable air conditioner.

2.1 System components

The system consists of TE (TEC-12076 x 4 Nos), a cold heat sink (40 mm x 60 mm x 40 mm), evaporator blower fan (7 CFM x 2 Nos), hot water box (120 mm x 40 mm x 10 mm), condenser blower fan (10 CFM x 1 No), radiator act as hot heat sink (200 mm x 20 mm x 100 mm), electronic water pump (2 L/min), copper pipe, biodegradable fiber cartridge act as evaporative cooling, power supply (30 A, 12 VDC), an Arduino Uno, thermostat, and a casing. The TEC air conditioner condensed by evaporative cooling casing is made of wood with inner insulation using polyethylene with a thickness 10 mm. Clear visualization of the setup is presented in Section 3.5.

Naturally, TEC Module provides cooling and heating by connecting the TEC plate to the electrical supply [11]. It can be used as cooler and heater simultaneously as the voltage supply to the Thermoelectric. The plate has two sides which are one side hot and the other side cool. The cold energy generated can be transferred to the evaporator heat sink by conduction. This heat distribution method has been employed by many researchers to increase the performance of the TECs, such as in [9, 12]. In order to enhance the absorption of sensible heat and latent heat of the surrounding, blower is attached at the evaporator heat sink act as forced convection.

However, there are different methods used in the hot side of TEC plate, whereby the hot energy generated undergoes the treatment by evaporative cooling technology. The high energy on the hot side was transported to the radiator through copper pipe before it is treated using evaporative cooling. The work in [13] stated that evaporative cooling can be applied as pre-cooling or energy recovery system recirculating before release the exhaust air to ambient. In this study, Evapolar with biodegradable fiber cartridge will be the equipment for evaporative cooling. Figure 1 is the diagram to illustrate the system.

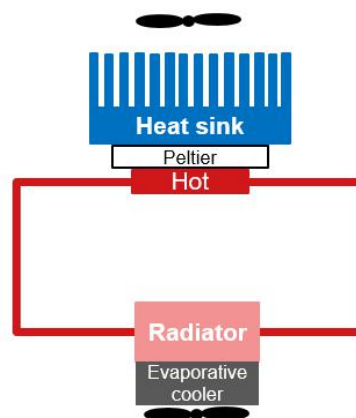

Figure 1. Illustration of TECs Air conditioner condensed by evaporative cooling system.

The system is powered by a 30 A/12 VDC power supply to operate certain parts of the product such as the thermostat, evaporator and condenser blower, TEC plate, and water pump. The controller of the system uses Arduino to act as resistor to control the amount of current flow to TEC. Thermostat is used to receive an input from user to control the product functioning such as the amount of electric current and speed of the blower. Figure 2 is the wiring diagram of the product to illustrate the controller of the system.

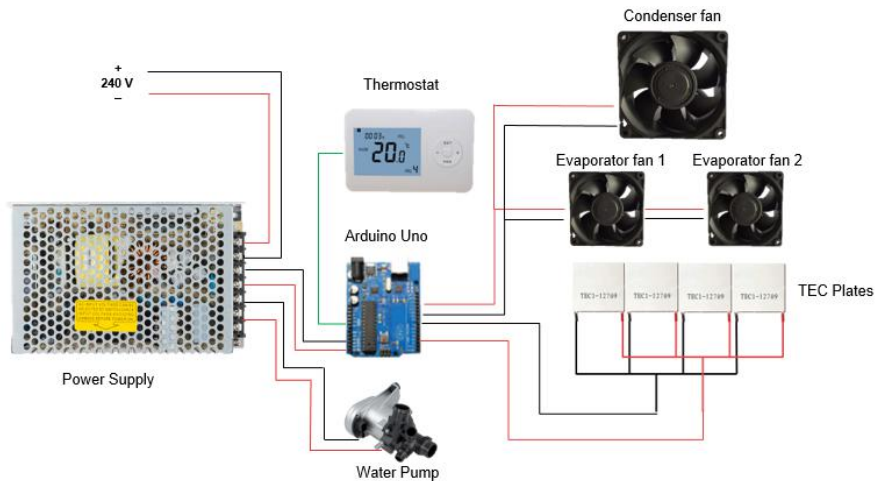

Figure 2. Schematic wiring diagram of TECs air conditioner condensed by evaporative cooling system.

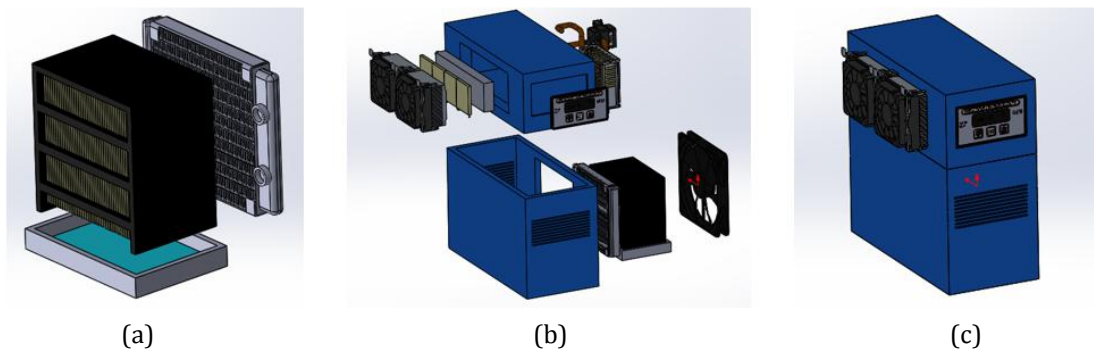

Figure 3. (a) Evaporative cooling system (b) Exploited view of the system (c) TEC air conditioner condensed by evaporative cooling.

The TEC is flanked by evaporator heat sink and water box. Evaporator heat sink and blower fan attached act as evaporator in this system which supply the cold air to the surrounding. The water box, radiator and evaporative cooler will be the condenser of the system. Plain tap water is used as medium to transport heat from the hot side of TECs to a radiator to distribute the heat. The pipe circulation is from water box to radiator and it uses a water pump to create a complete water circulation. Next, the hot radiator will be treated using evaporative cooler before releasing the heat to the surrounding. Evaporative biodegradable fiber cartridge in Figure 3 (a) is used to act as an evaporative cooling where the Evapolar pitch is channeled into the water tank to absorb the water and create an evaporative cooling mechanism. Additional blower is attached to the Evapolar to increase the rate of heat transfer in this system. Assembly of component is described in Figure 3 (b) and (c).

2.2 Experimental area

The dedicated area chosen was a faculty office at the University Teknikal Malaysia Melaka (UTeM) where the room location is facing West. The private office cooling load was not as much as a factory and any large space because of the area and volume of space influences the cooling load. The bigger the space the bigger the area that expose to the sunlight and the higher chances of external load to entering the space. Simulation of cooling load was run using a heat load calculator, this area contains 4267 btu/hr and requires less than 1 hp equipment to remove the load. The red star indication shown in Figure 4 is where the product being tested. During the execution of experiment, the test area must not have another air conditioning system servicing the dedicated space in order to obtain precise results. In addition, the atmospheric air condition for test area has been measured before the experiment begin as shown in Table 2.

Table 2 Initial atmospheric air condition for test area

Ambient condition	Value
Dry bulb temperature	30°C
Wet bulb	$T_{wbt} = 20.1^{\circ}\text{C}$
Humidity ratio	$w_a = 10.646 \text{ g/kg}$
Specific heat of air	$C_{pa} = 1.007 \text{ kJ/kg}\cdot\text{K}$
Specific heat of vapor	$C_{pv} = 1.996 \text{ kJ/kg}\cdot\text{K}$
Density of air	$\rho = 1.1652852 \text{ kg/m}^3$

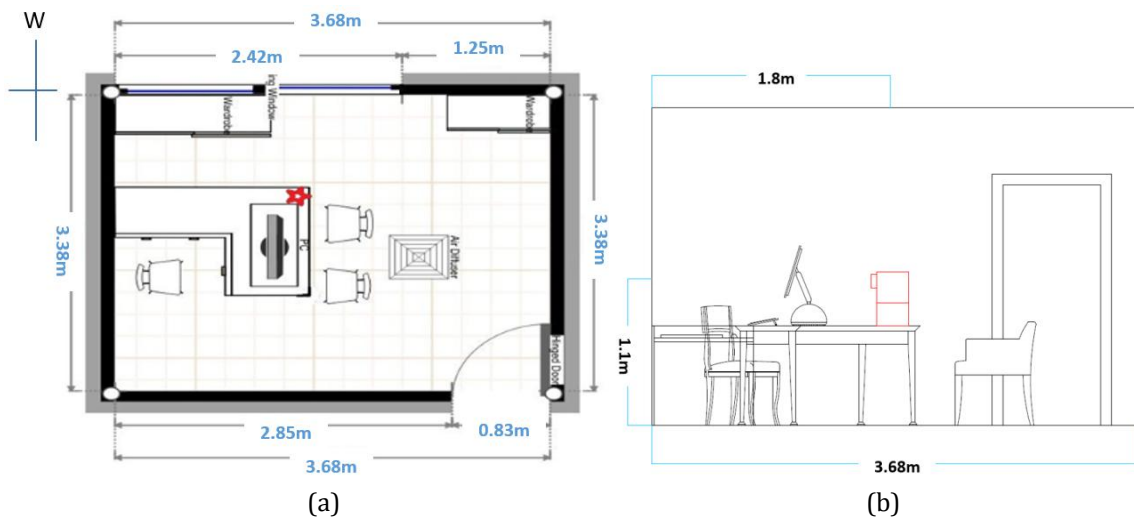

Figure 4. Drawing layout of Private Office in UTeM, (a) Top view, and (b) Side view.

2.3 Experimental procedure

Turning on the portable air conditioner by supply of 12 DCV to the portable air conditioner. All components will automatically run due to the electrical schematic design. Hot water supply with flow rate 2 L/min is continuously supply to radiator once the unit running. The radiator act as medium to extract the heat before it treated by evaporative cooling and release the waste energy to surrounding. Two electronic blowers will generate a 7 CFM each at the evaporator blower and 10 CFM electronic blower at the condenser section in order to suck out the heat

energy to surrounding. Controller of the unit controlling the varies current supply to the TECs and provide different cooling effect. Once the unit start, the current is set at 1 A and it can increase up to 6 A.

The current supply act as the manipulation variables in this experiment to determine the finding of this study which are the optimum running current and the coefficient of performance of the product. Set 1 A current supply at the TEC and collect the data at selected point. Two different tap points of thermocouple in this study which are at both sides of TEC Plate and the conditioned supplied air from the air conditioner. Thermocouple are pointing the selected tap point on both side of the TEC Plate after running 2400 s. Next, the data recorded 1.5 m peripherally around the air conditioner at the point A, A', B, B', C, C' as Figure 5. The data taken from the point will be averaged to precise the data measured. The experiment was conducted for about 3600 s in the personal office and measured every 10 minutes.

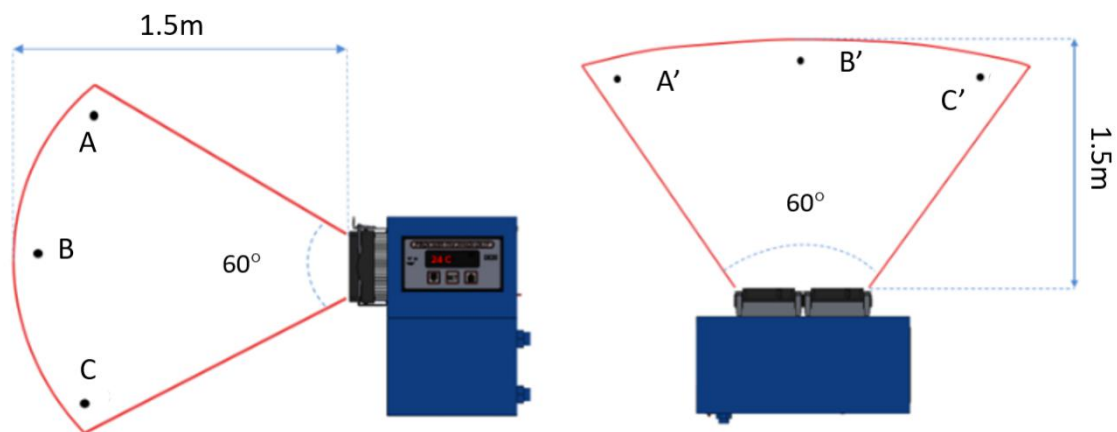

Figure 5. Tap points of supplied temperature of the system.

Third, measure the dry bulb temperature and relative humidity at point T_1 , before entering the evaporative cooler for each 10 minutes. At the same time measure the data of air leaving the evaporative cooler, T_2 . This method was used by [14] where they demonstrated the performance of direct evaporative cooling system and [15] experimented on COP of evaporative cooling in residential building in summer. The location of the data recording points as shown in Figure 5.

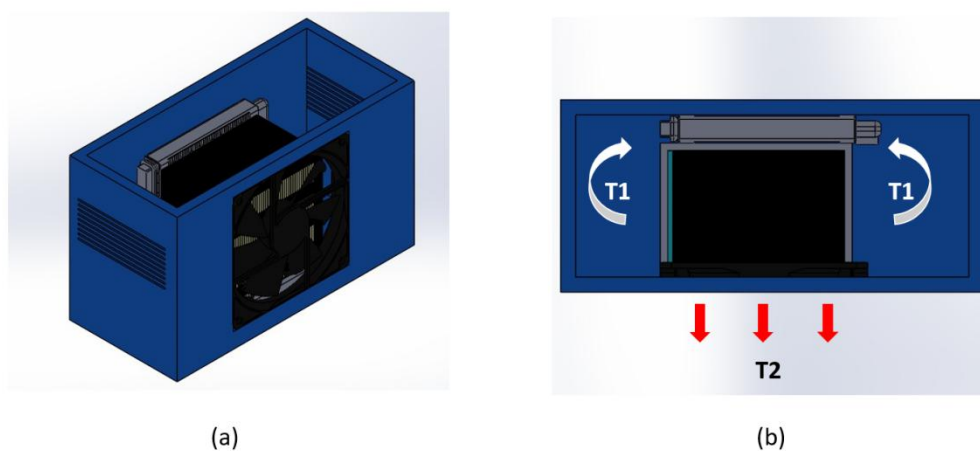

Figure 6. Isometric view of condensing system of TEC air conditioner (b) Top view of condensing system of TEC air conditioner.

Then, the experiment is repeated by using the different current supplies like 2, 3, 4, 5 and 6 A and all the data was recorded using MS Excel without changing any other variables, because this study aims to determine the performance of the system and the optimum running current for the system.

Next, the sound level of the unit for two conditions is measured which are in the private office and the acoustic room in order to determine the sound level of the TEC air conditioner. In the private office, the spot to put the sound level meter for measuring sound level of private office room and measuring sound level of an office room with portable air conditioning was the same which was at the nearest area to occupant where the red star indicates in Figure 4. While in the acoustic room, the sound level meter was situated at the center area of the room for measuring sound level of acoustic room with and without portable air conditioning. Finally, the data results were obtained and summarized in the software of the data logger sound level meter.

2.4 Data reduction

The main goal of this study is to determine the performances of the TEC air conditioner condensed by the evaporative cooling system. The performance of the system can be extracted from data of (a) TEC performance by various current supply, (b) power consumption of the device against temperature difference of hot and cold sides of the TEC, (c) COP of the system (d) optimum current for the system and (e) efficiency of evaporative cooler. The bottom line is that all the data measured should achieve the [16] or [17] definition of comfort zone temperature. Consequently, the performance coefficient can be found as.

$$COP_p = \frac{Q_p}{P_p} = \frac{SIT_c - K(T_h - T_c) - 0.5(I^2R)}{P_p} \quad (1)$$

In the application of refrigeration, the coefficient of performance of a thermoelectric module, COP_p is defined as the ratio of the heat flux through the cold surface of the module, Q_p to the electrical power consumed by the module, P_p . S is the Seebeck effect coefficient of the TEC 12076, K is the module's lattice thermal conductivity, I that is the current entering the TECs, and R is the electrical resistance. In Equation (1), the calculation of the cold side heat flux of the thermoelectric module is calculated by electrical power consume measured value, which is slightly different from the calculated values based on the difference of hot and cold side heat flux. This is because to obtain the real COP of the TECs on this case study. Besides, this methodology has been used in previous study who are seeking for the multiple condition of heat removal to obtain the exact COP in the real case of [12]. Next, the air cooling energy can be found as

$$Q_{air} = \dot{m}_{air} C_p \Delta T_s \quad (2)$$

Here, \dot{m} is the mass flow rate of the evaporator blower, C_p is the specific heat of air and T_s is the temperature of the supply air. Important thing that should be concern, the value Q_p in Equation (1) is should be lower than Q_{air} in Equation (2) because Q_p is absolute cooling energy generated by the TECs while Q_{air} is amount of heat absorbed from the surrounding to reduce the temperature. Coefficient of Performance of the TECs air conditioner condensed by evaporative cooling is shown below as

$$COP_c = \frac{Q_{air}}{P_e} = \frac{\dot{m} C_p \Delta T}{\sum W} \quad (3)$$

Total power consumption P_e is the summation of all the power consumed for the system including the auxiliary components as shown earlier in Table 3 and the power consumed for the TEC depends on various current supply as shown in Table 4.

Table 3 Auxiliary components and rated power

Components	Qty	Rated Volt (V)	Running Ampere (A)	Total Rated Power (W)
Evaporator Blower	2	12	0.08	1.92
Condenser Blower	1	12	0.1	1.2
Water Pump	1	12	0.15	1.8

Table 4 Power consumption of TEC in various current

Supply Current (A)	Measured Value of TECs (W)	Total value $\sum W$ (W)
1	15.3	20.22
2	23.4	28.32
3	39.9	44.82
4	53.1	58.02
5	61.1	66.02
6	71.3	76.22

All the data above was measured using the multi-meter and digital clamp meter for each component of auxiliary and TEC in the system. Data measured by clamping the wire while running the system was to obtain the exact running consumption. Next, the performance of evaporative cooling is important to produce a good TEC air conditioner as the evaporative cooler is the condensing unit for the system.

Properties of atmospheric air are calculated from engineering equation solver with respect to dry bulb temperature and relative humidity. This ambient condition is taken for thermodynamic analysis of different configurations of cooling media in the direct evaporative cooling system. Consequently, the specific heat of moist air can be calculated by the following equations.

$$C_{pu} = C_{pa} + w_a C_{pv} \tag{4}$$

$$Q_{evp} = \dot{m}_{air} C_{pu} \Delta T_{evp} \tag{5}$$

$$COP_{evp} = \frac{\dot{m}_{air} C_{pu} \Delta T_{evp}}{W_{condenser}} \tag{6}$$

Here, C_{pa} is the specific heat of air in kJ/kg·K, w_a is the humidity ratio of the air, C_{pv} is specific heat of vapor, Q_{evp} is the cooling energy generated by the evaporative cooling, ΔT_{evp} is the temperature different of supply and return air.

3. RESULTS AND DISCUSSION

The product was made according to the design by the selection using characteristics of engineering obtained from the morphological chart where the combination of specific conditions for the creation of a masterpiece product as shown in Figure 6. The technology featured in the system are Peltier as a cooling source, heat sink with aluminum fins to improve the heat transfer rate, wood casing to protect the internal component, Evapolar biodegradable fiber as a medium to cool down condenser, and the fan to blow cool air.

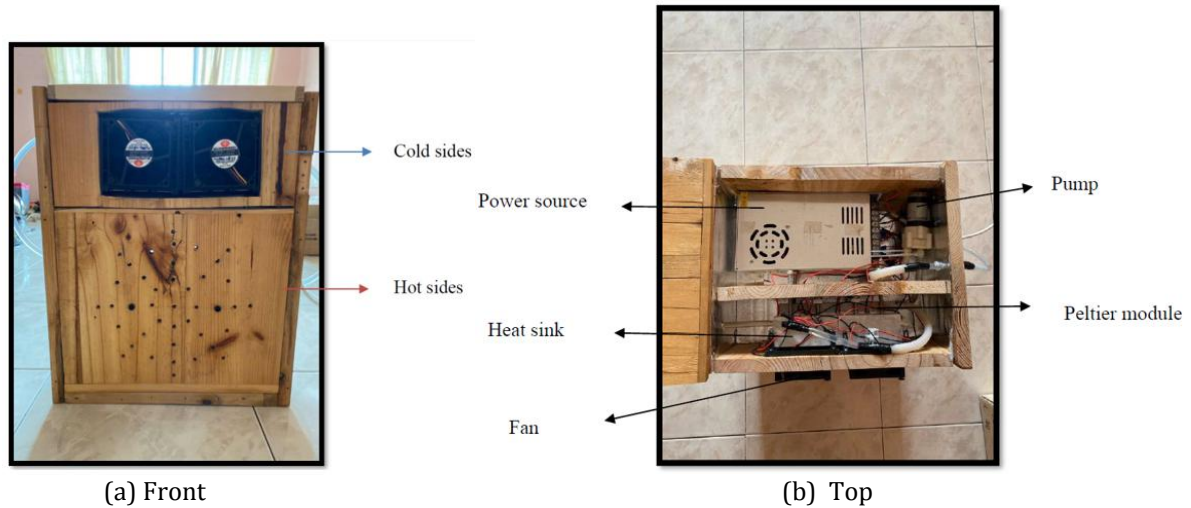

Figure 6. The experimental setup of the TEC air conditioner condensed by evaporative cooling.

3.1 TEC performance by various current supplied

The TEC hot and cold side temperatures play important roles in evaluating the TEC performances because the temperatures obtained are the required data in Equation (2). In this study, the TEC hot and cold sides are flanked with water heat sink box and fin heat sink respectively and it is difficult to measure TEC hot and cold side temperatures, T_h and T_c directly. Hence, the position of the measurement points is changed to the surface of water heat sink box and fin heat sink nearest the surface of TEC plate due to the critical TEC measurement points. [18] conducted an experiment to obtain the performance of TEC cooler condensed by microchannel heat had encounter this measurement problem as the TEC plate is bonded with microchannel heat sink and measured the surface that nearest to the TEC plate.

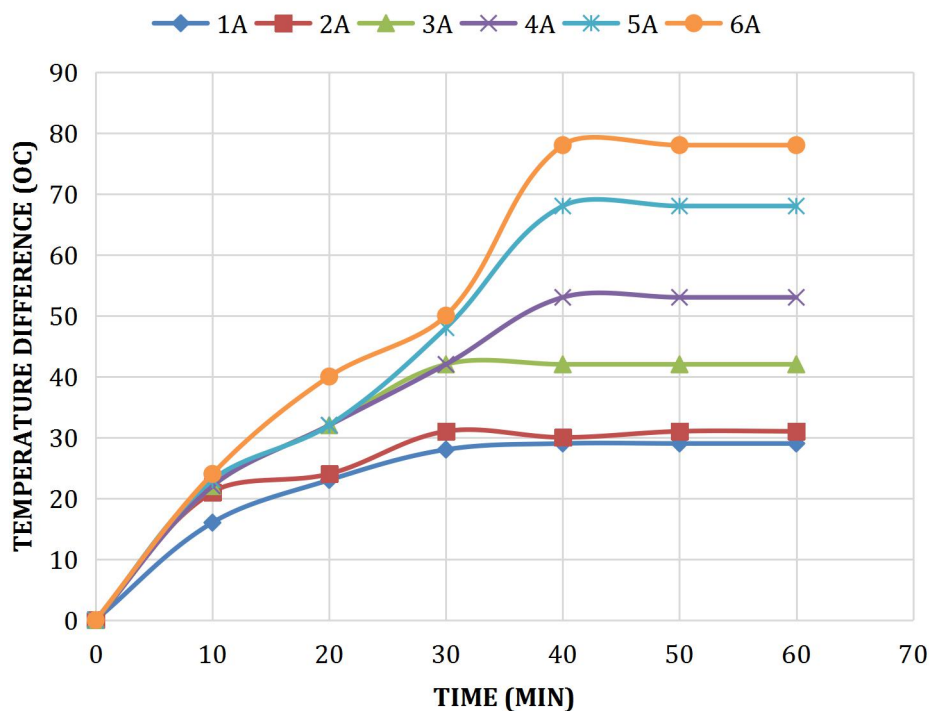

Figure 7. Graph of temperature difference between hot and cold side of TEC versus time at various current supply.

The surface temperature of TEC has strong relationship with the various of current supply. In Figure 7, it is clear that the increment of current would result higher temperature different between hot and cold side as the pattern of the graph is slowly increase in period of time. Moreover, the increment of current supply would increase the temperature difference between hot and cold side. The temperature difference between hot and cold side is affected by the heat flux through the TEC surfaces. The trends of temperature difference for various current supplies reach a steady state at certain time respectively. This study assumes the steady state temperature is the temperature when it reaches the plateau condition. Therefore, the maximum and minimum temperature obtained indicate the equilibrium condition of TEC. The initial point of steady state indicates the time that TEC reach the equilibrium as well as the maximum and minimum temperature for both side. In this study, the fastest time that reach steady state is 30 minutes by running the TEC with 1 A and able to produce 48 °C and 20 °C of maximum and minimum temperature for both sides.

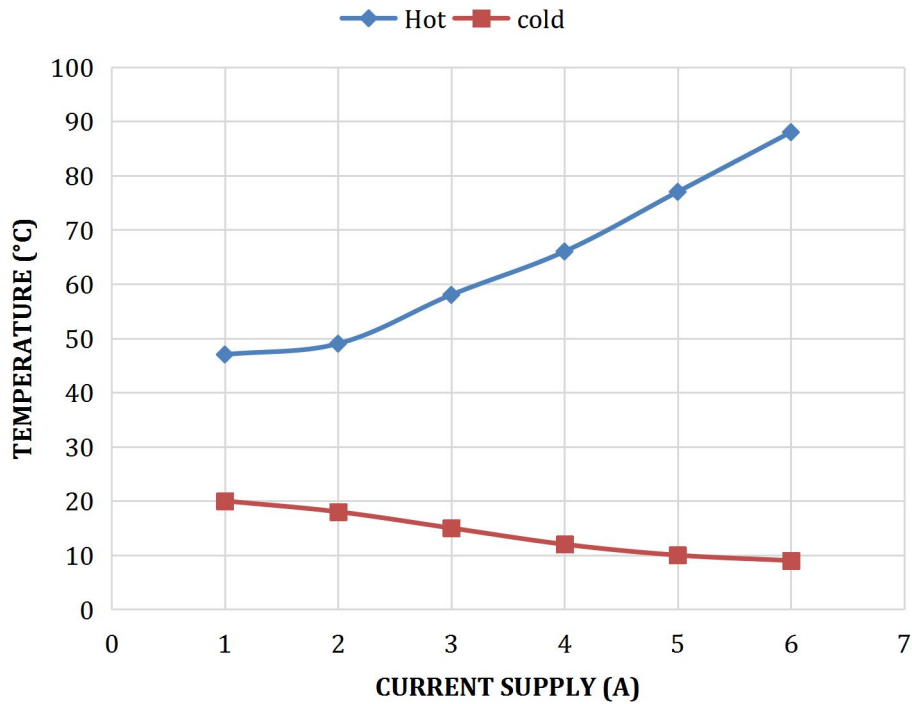

Figure 8. Maximum and minimum temperature of TEC generated versus current supply.

Figure 8 shows the maximum temperature for hot side and minimum temperature of cold site for each current. The graph intention is to relate a strong connection between current temperature obtained. As a result, the current supply affected the temperature for both sides where the increment of current would increase the temperature of hot side and decrease the temperature of cold side. Obviously, the higher the current supply to the TEC, the higher the temperature difference between hot side and cold side. Researchers in [19] evaluated the performance of TEC under real condition One of the finding in this study was that the voltage and current affected the temperature difference between surfaces where bigger gap surface temperatures would present better performance. Perhaps, the cooling effect of the TEC absorbs the heat in the dedicated area to provide comfort zone is the main explanation. In other words, the graph above shows that a TEC with higher current supply creates more cooling effect which is able to reduce the cold side temperature and produce a higher temperature of hot side at the same time. The cold side will be the element which absorbs the heat from the surrounding and the hot side will be the heat waste in this case. Thus, evaporative cooling acts as heat removal in this system in order to reduce the temperature of hot side TEC.

3.2 COP of TEC air conditioner by evaporative cooling

The COP of the TEC was calculated using measured data at 40th minute because most of the current became steady by this time as shown as Figure 7. The COP determined by making constant the variable for auxiliary component and only vary the power consumption of the TEC. According to Equation (3), COP of TECs obtain in this project is 0.39 which is slightly increased by 29% from previous study whereby using a direct water cooling the heatsink obtained 0.3 of COP as reported in [12]. It shows that, treatment using water cooled and additional of evaporative cooling able to increase the COP of the TEC.

In Figure 9, the red straight line is referring to 24°C which is the desired temperature of this study. In addition, 24°C is acceptable temperature of comfort zone or a set point in this case study and the result obtained would consider not pass if not able to reach the set point. It

evaluates the supply air temperature that been measured 1.5 m peripherally by various current supply toward TEC. The pattern of the graphs is indirectly proportional as the temperature starting to drop as time increasing. Based on red indicator set point temperature, 1 A and 2 A current could not reach the thermal comfort zone within the testing period. When supplying low current toward TEC it produces low heat flux through the surface of TEC as amount of current would affect the maximum and minimum temperature of both sides. In addition, the heat loss from cold side of plate to the fin heat sink during the conduction process would affect the supply air temperature.

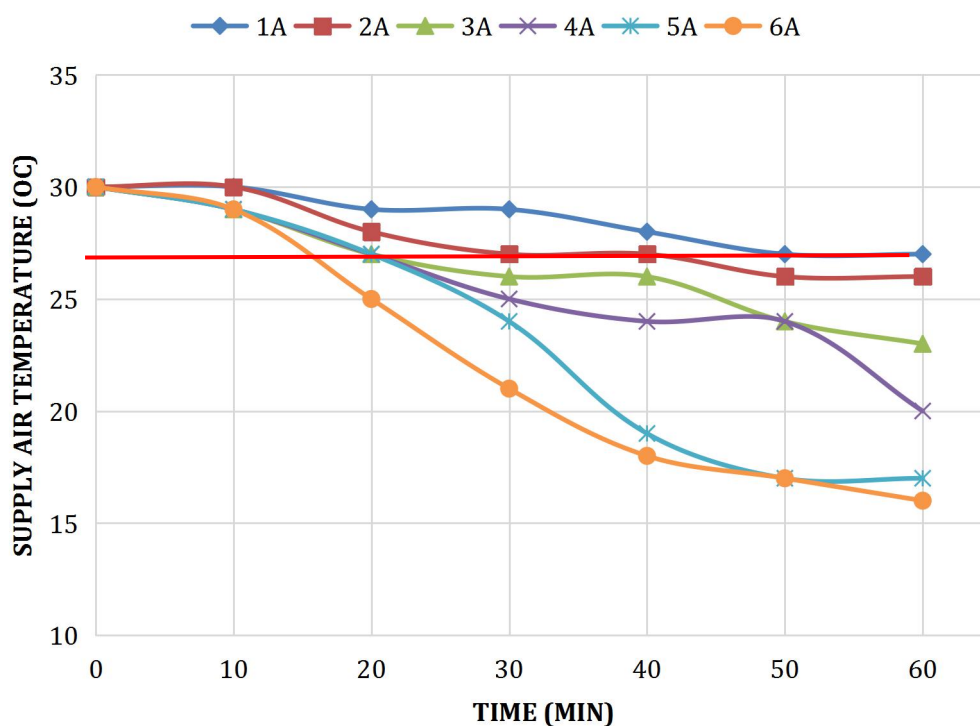

Figure 9. Graph of supply temperature produced by the system against time.

On the other hand, 3, 4, 5, and 6 A successfully reached the set point temperature within the testing period. As a result, each running current able to drop the ambient temperature within the 1.5 m peripheral area to a set point at different times. In Figure 9, the time taken to achieve thermal comfort temperature of this study are (i) 55 (ii) 40 (iii) 31, and (iv) 23 minutes for 3, 4, 5 and 6 A respectively. Obviously, higher current supply would shorten the time to product reach the desired temperature. Amount of current supply to TEC and temperature of cold side has strong proportional relationship as increment of current could decrease the temperature of the cold side. Hence, the low temperature of cold side act as important role to shorten the time taken to achieve set point temperature.

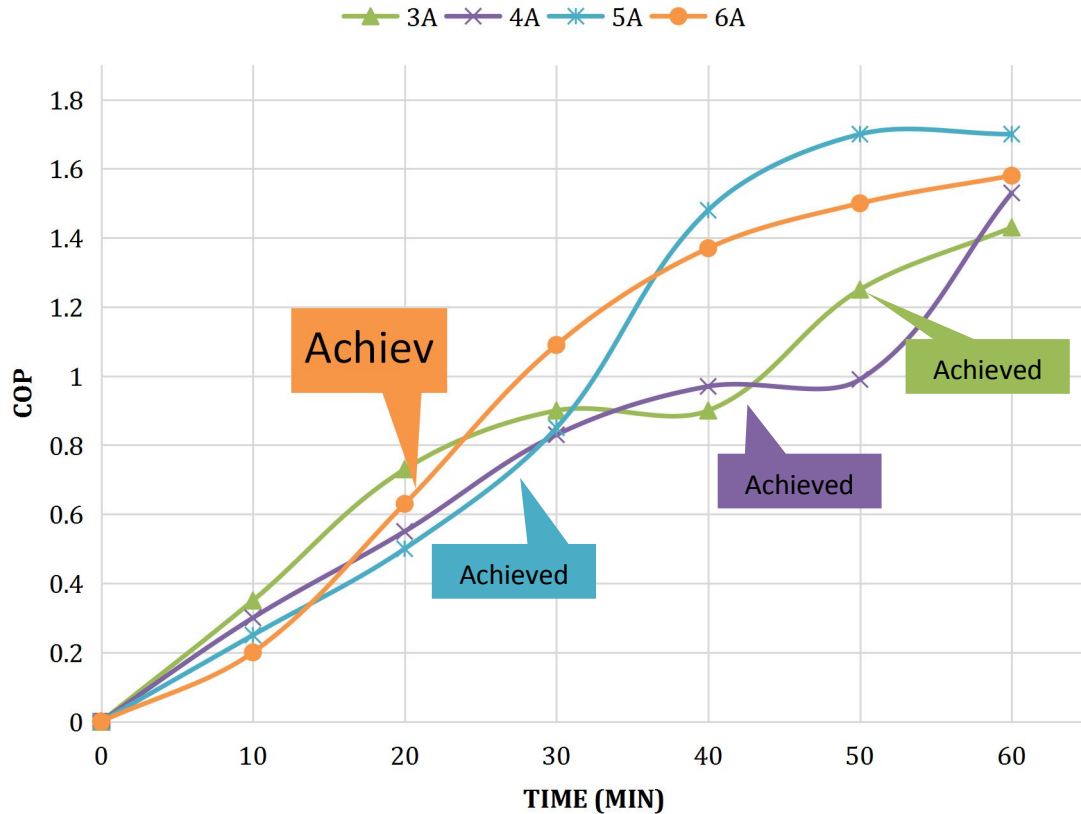

Figure 10. Graph of COP extracted for each current supply against time.

According to the graph in Figure 10, this study only focused on the current supply and its effects on the surrounding to reach the thermal comfort zone. In result, various of COP obtained and different time taken for each current supply to TEC to achieve 24°C. This graph also shows that there is not a big difference at the end of the experiment. In the 60-minute period of data taking found that the COP are (i) 1.445, (ii) 1.536, (iii) 1.718, and (iv) 1.594 for 3, 4, 5 and 6 A current supply respectively. In a related development, researchers in [20] reported maximum values of COP obtained when they increased the electric current. The highest COP was achieved using 5 A current supply because the power consumed is less but the cooling effect was almost similar as that with 6 A current because the difference between supply air temperature of 5 A and 6 A is 1°C. The cooling energy is released out to the surrounding and this drops the temperature of the return air. The low temperature return air of the system might have helped to enhance the cooling effects of the system.

Evidently, the 3 A running current was the highest COP for the system as the COP graph is increases with time. However, the time taken for it to achieve comfort zone was still long and not convenient for air conditioning application. This study also found that the 5 A running current would be the best and optimum to suit the air conditioning application because the time taken to drop the surrounding temperature to the desired set temperature was slightly different from the output with 6 A current, which was a 5-minute difference between these two supply currents. In addition, 5 A running current produced a higher COP for a long running period of the system as the Figure 10 shows that at the end of the experiment, it achieved the highest COP that was 1.718.

3.3 Evaporative cooling performance

The evaporative cooling plays an important role in the development of an air conditioner by a condensing approach that removes the heat generated by the hot side of the TEC plate. In this

study, the heat from hot side was dissipated via water to the radiator to increase the surface area of heat transfer via the evaporative cooling process that forced a constant 10 CFM of air flow rate to the ambient temperature. The COP of evaporative cooling that is defined as the ratio of heat removed from the hot side of TEC to work energy input in that particular system. The data obtained by measuring the air entering temperature, T_1 and the temperature of air leaving the evaporative cooler, T_2 that would be very useful to determine the COP of evaporative cooling.

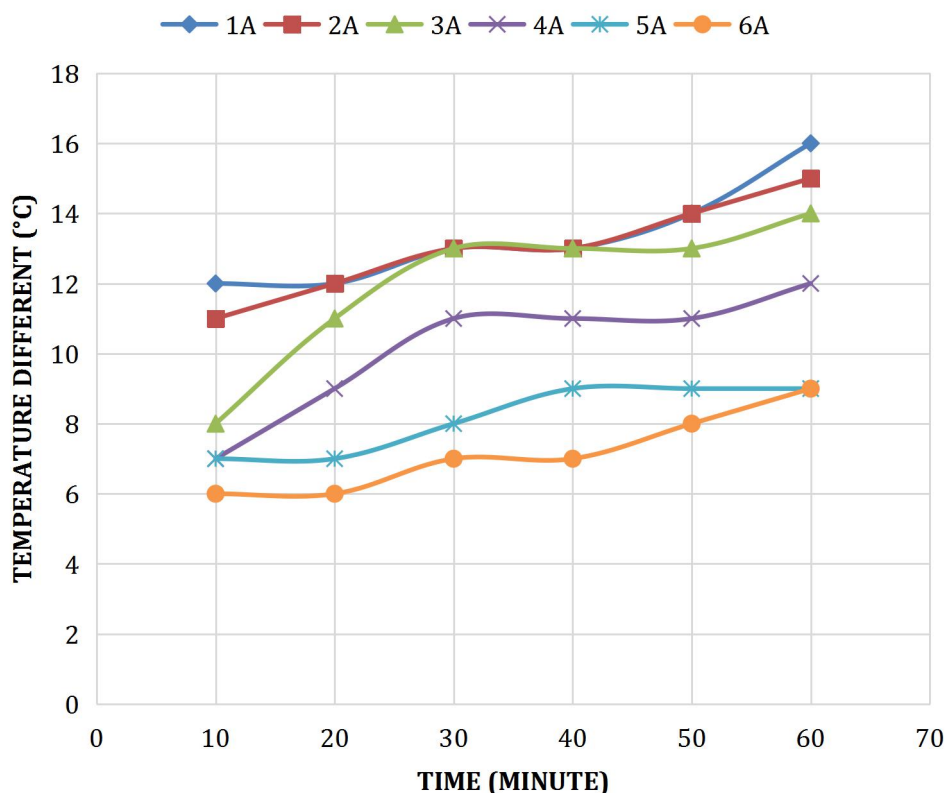

Figure 11. Temperature different of evaporative cooling along the time.

The graph in Figure 11 shows temperature difference of air after go through the process of evaporative cooling. The plots exhibit almost steady increase through the end of the process as the system absorb more heat energy from the radiator and increase the temperature of T_1 that would produce higher temperature difference with time. Next, the various current supply to the TEC resulted in a variety of temperature differences and the result obtained in this study showed that the higher current supply would decrease the temperature difference between entrance and exit of the evaporative cooling system. This is because the current supply is affected by the temperature of TEC as shown in Figure 8 and the cooling energy of evaporative cooler generated in this study is not capable to maintain the temperature different as good as running with 1 A. The limitation of this product only allows it to provide constant air flow rate that causes the temperature difference in air to remain the same with an average of 12 °C. Forced convection by an electronic blower that produced 20 kg/hr of air mass flow rate. The mass flow rate is a parameter that is necessary to consider in achieving the highest efficiency in the evaporative cooling process. According to [14] as well as [21] the experimental works on various of wetted area types found that the system required more air mass flow rate and the area of wetted surface in order to increase the cooling capacity in evaporative cooling.

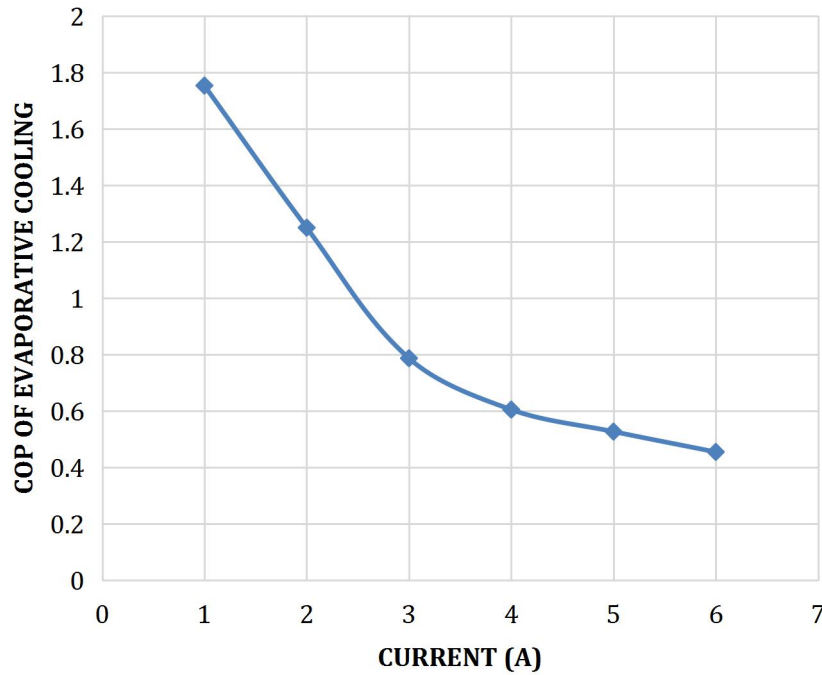

Figure 12. The COP of the evaporative cooling versus current supply.

The result in Figure 12 shows the downward trend of the plot that means the higher current supply resulting in lower COP in evaporative cooling. The evaporative cooler is only efficient if the entering air temperature is close to the room ambient temperature, 30°C because of the limitation of the cooling media, which is biodegradable mineral fiber used in this study as wetted area that is practical to condition the air in the room. Consequently, 1 A and 2 A current settings were able to achieve more than unity value of COP that means the cooling system generated more energy than the electrical energy consumed by the developed product. Unfortunately, running the developed product with 1 A and 2 A supplies could not provide the thermal comfort zone as evident in Figure 9, even though the result of evaporative cooling COP is higher compared with the COP's of other electrical current values. In other hand, the highest COP of TEC air conditioner at the end of the process is running by 5 A as shown in Figure 10 would result 0.53 COP of evaporative cooling.

3.4 Sound analysis of TEC air conditioner by evaporative cooling

Next, the sound level was studied. Researchers in [22] conducted an experiment to study the sound level of axial fan in the indoor unit air conditioner in the acoustic room. That study analyzed noise by using both experiment and numerical simulation. The intention was to understand the generation of sound mechanism and to predict the flow field and acoustic pressure field. The investigators in [23] studied the source of the sound of the residential split air conditioner. The outdoor components of the system were neglected in this study and only analyzed the indoor sound level by increasing the airflow rate by 5 different speeds of the blower.

In the current work, for the background sound, most of the time the sound level was between 35 dB and 40 dB in each ten minute's interval. Only occasionally did its sound level exceed 40 dB. While for the primary sound the data looks nearly uniform at the time of measurement which is between 68 dB and 69 dB. The average value between the maximum and minimum value of both background and the primary sound level were 37.4 dB and 68.7 dB. The average increment of the sound level after the TEC air conditioner was located in a private office room was about 31.3 dB. Table 5 shows the details of the results obtained from the sound level meter device.

Table 5 Comparison between background sound and primary sound in an office space

Features	Background sound	Primary sound
Date	Wednesday, 13 November 2019	Wednesday, 13 November 2019
Testing Venue	Private Office Room, F3 Building.	Private Office Room, F3 Building.
Device Model Type	SOUND LEVEL METER (SE-390)	SOUND LEVEL METER (SE-390)
Start Time	14:41 PM	15:04 PM
Stop Time	14:51 PM	15:14 PM
Sampling Rate	10 Seconds	10 seconds
No of data recorded	60	60
Sound level (THEORY)	50 dB (Private Office Room Sound Level)	
Sound level (TESTING)	Maximum: 48.4 dB Minimum: 35.3 dB	Maximum: 68.9 dB Minimum: 68.5 dB
Average of Sound level (TESTING)	37.4 dB	68.7 dB

The background sound was measured to determine the tested area sound level excluding the TEC air conditioner. Based on Table 5, the background sound obtain is 37.4 dB which is below than the acceptable range of sound level for office application. Once running the TEC air conditioner, the sound level was increased to 68.7 dB, which already exceeded the acceptable range for quite office application. Nevertheless, the result obtained was still below the acceptable OSHA (Occupational Safety and Health) sound exposure limit standard as it allowed the exposure limit of 90 dBA for workers with 8-hour time limitation [24]. In this case study, the noise of the device is significantly below that noise level.

4. CONCLUSION

The main objective of this work was to test the performance of TEC air conditioner by evaporative cooling as heat waste management. The TEC performance obtained in this project was 0.39 that shows the treatment using water-cooled and additional evaporative cooling was able to increase the COP of the TEC. The higher current supply would shorten the time taken to achieve thermal comfort zone of 24°C as current supplied affected the cooling capacity of a TEC. Hence, COP of the TEC air conditioner condensed by evaporative cooling was very effective while running using 5 A current supply and was able to obtain 1.718 COP. Next, the COP of evaporative cooling by supplying 5A is 0.53. Lastly, the sound level of a TEC air conditioner was analyzed for personal use and it should be installed inside the personal office. The data showed that the average sound level was 68.7 dB which is still acceptable according to the Occupational Safety and Health guidelines.

ACKNOWLEDGEMENTS

The authors would like to appreciate the support and assistance by staff at the laboratories and researchers as well as the Universiti Teknikal Malaysia Melaka (UTeM).

REFERENCES

- [1] Sumeru, K., Tritjahjono, R. I., Setyawan, A., Sukri, M. F., Journal of Advanced Research in Fluid Mechanics and Thermal Sciences, **55**, (2019) pp.1-11.
- [2] Solomon, S., Mills, M., Heidt, L. E., Pollock, W. H., Tuck, A. F., Journal of Geophysical Research: Atmospheres, **97**, (1992) pp.825-842.
- [3] Benhadid-Dib, S., Benzaoui, A., Energy Procedia, **18**, (2012) pp.807-816.
- [4] Kim, M. H., Bullard, C. W., Energy, **26**, (2001) 931-948.
- [5] Park, Y. C., Kim, Y. C., Min, M. K., Energy Conversion and Management, **42**, (2001) pp.1607-1621.
- [6] Dhumane, R., Ling, J., Aute, V., Radermacher, R., Applied Energy, **208**, (2017) pp.390-401.
- [7] Yun, G. Y., Lee, J. H., Kim, H. J., Energy and Buildings, **116**, (2016) pp.638-645.
- [8] Sahu, S. K., Cooling Load Estimation for a Multi-Story Office Building, NIT Rourkela, (2014).
- [9] Mirmanto, M., Sayoga, I. M., Sutanto, R., Alit, I. B., Nurchayati, N., Mulyanto., Frontiers in Heat and Mass Transfer. **10**, 34, (2018) pp.1-7
- [10] A. Çağlar, Applied Thermal Engineering, **149**, (2019) pp.822-828
- [11] Dai, Y. J., Wang, R. Z., Zhang, H. F., Yu, J. D., Applied Thermal Engineering, **21**, (2001) pp.185-201.
- [12] Liu, Y., Su, Y., Applied Thermal Engineering. **144** (2018) pp.747-756.
- [13] Git, H. M., Seng, O. K., Gilani, S., Aris, M., Asian Journal of Scientific Research, **6**, (2013) pp.528-536.
- [14] Dhamneya, A. K., Rajput, S. P., Singh, Journal of Building Engineering, **17**, (2018) pp.52 - 54.
- [15] He, W., Xilian, L., Yuhui, S., Min, Z., Zhaolin, G., *Energy Procedia*, **152**, (2018) pp.928 - 934.
- [16] ASHRAE-55 Thermal Environment Conditions for Human Occupancy, American Society of Heating, Refrigerating, and Air-Conditioning Engineers, Atlanta, GA, (2017) pp.1-66.
- [17] MS 1525:2014 Energy efficiency and use of renewable energy for non-residential buildings- Code of practice (Second revision), Department of Standards Malaysia, Cyberjaya, Selangor, (2014) pp.8.
- [18] Chein, R., Chen, Y., International journal of refrigeration, **28** (2005) 828-839.
- [19] Ibañez-Puy, M., Bermejo-Busto, J., Martín-Gómez, C., Vidaurre-Arbizu, M., Sacristán-Fernández, J. A., Applied Energy, **200**, (2017) pp.303-314.
- [20] Zhou, Y., Zhang, T., Wang, F., Yu, Y., Energy, **162**, (2018) pp.299-308.
- [21] Cui, X., Yan, W., Liu, Y., Zhao, M., Jin, L., Applied Energy, **271**, (2020) pp.115238.
- [22] Jiang, C. L., Chen, J. P., Chen, Z. J., Tian, J., OuYang, H., Du, Z. H., Applied acoustics, **68**, (2007) pp.458-472.
- [23] Crocker, M. J., Arenas, J. P., Dyamannavar, R. E., Applied Acoustics, **65**, (2004) pp.545-558.
- [24] Occupational Safety and Health Standards: 1910 Subpart G, US Department of Labor, Washington D. C., (2006).

